

# BOOMILEVER

## Loading Block Assembly and Bucket Stabilization Sticks – 2021

### Loading Block Assembly (Top View)

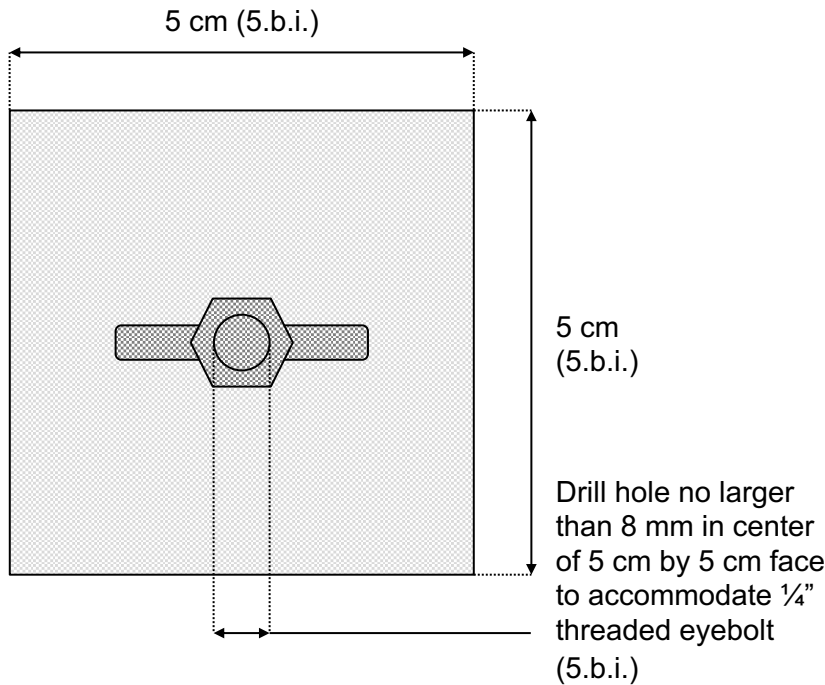

### Loading Block Assembly (Side View)

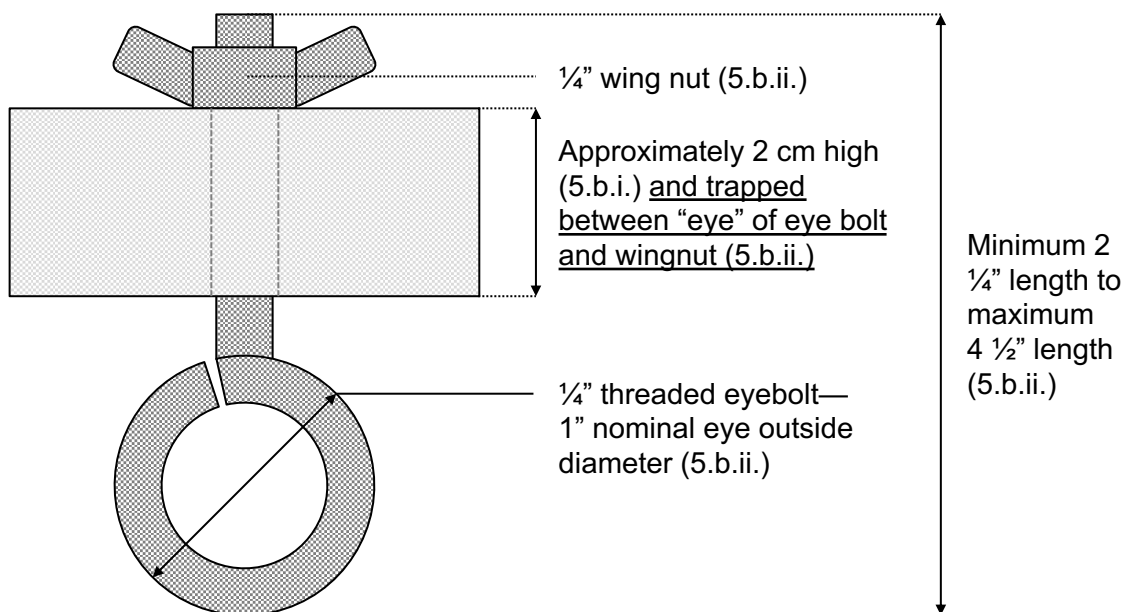

Total combined mass of Loading Block, eyebolt & wingnut, chain & S-hook, and five-gallon plastic bucket **may not exceed 1.5 kg** (5.b.v.)

### Bucket Stabilization Sticks (Provide 2)

